

Transient Voltage Suppressors (TVS) DataSheet

Features

- 600W peak pulse power capability at 10/1000μs waveform, repetition rate (duty cycle): 0.01%
- High Temperature soldering: 260°C/10 seconds at terminals
- Plastic package has underwriters laboratory flammability 94V-0
- Meets MSL level 1, per J-STD-020
- Typical I_R less than 1μA above 10V
- AEC-Q101 qualified
- For surface mounted applications in order to optimize board space
- Low inductance
- Fast response time
- Low profile package
- Glass passivated junction
- Excellent clamping capability

Functional Diagram

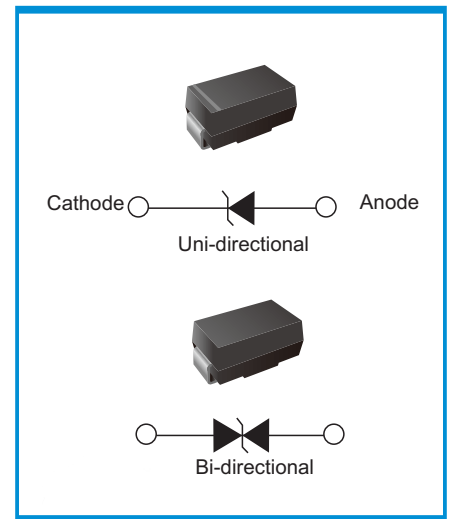

Mechanical Data

- Weight: 0.07g
- Standard Packaging: 12mm tape (EIA STD RS-481)
- Case: JEDEC DO-214AC. Molded plastic over glass passivated junction
- Terminal: Solder plated, solderable per MIL-STD-750, Method 2026
- Polarity: For uni-directional types the band denotes cathode end, no marking on bi-directional types

Applications

- I/O interface ■ AC/DC power supply ■ Vcc bus
- Low frequency signal transmission line (RS232, RS485, etc.)

Maximum Ratings and Characteristics

Ratings at 25°C ambient temperature unless otherwise specified.

Rating	Symbol	Value	Units
Peak pulse power dissipation at 10/1000μs waveform (Note1, Note2, Fig.1)	P_{PPM}	Minimum 600	Watts
Peak pulse current of at 10/1000μs waveform (Note 1, Fig.3)	I_{PPM}	See Table	Amps
Steady state power dissipation at $T_A=50^\circ\text{C}$ (Fig.5)	$P_{M(AV)}$	5.0	Watts
Peak forward surge current, 8.3ms single half sine-wave superimposed on rated load, (JEDEC Method) (Note3, Fig.6)	I_{FSM}	100	Amps
Operating junction and Storage Temperature Range.	T_J, T_{STG}	-65 to +150	°C
Typical thermal resistance junction to lead	$R_{\theta JL}$	20	°C/W
Typical thermal resistance junction to ambient	$R_{\theta JA}$	100	°C/W

Notes: 1. Non-repetitive current pulse, per Fig.3 and derated above $T_A=25^\circ\text{C}$ per Fig.2.

2. Mounted on 5.0mm×5.0mm (0.03mm thick) copper pads to each terminal.

3. 8.3ms single half sine-wave, or equivalent square wave, duty cycle=4 pulses per minutes maximum.

Electrical Characteristics (T_A=25°C)

Part Number (Uni)	Part Number (Bi)	Marking	Reverse Stand off Voltage V _R (Volts)	Breakdown Voltage V _{BR} (Volts)@ I _T		Test Current I _T (mA)	Maximum Clamping Voltage V _C @ I _{FP} (V)	Maximum Peak Pulse Current I _{FP} (A)	Maximum Reverse Leakage I _R @ V _R (μA)
				MIN	MAX				
LTVA5.0AJ	LTVA5.0CJ	5J	5.0	6.40	7.00	10	9.2	65.3	500
LTVA6.0AJ	LTVA6.0CJ	6J	6.0	6.67	7.37	10	10.3	58.3	500
LTVA6.5AJ	LTVA6.5CJ	6J5	6.5	7.22	7.98	10	11.2	53.6	300
LTVA7.0AJ	LTVA7.0CJ	7J	7.0	7.78	8.60	10	12.0	50.0	200
LTVA7.5AJ	LTVA7.5CJ	7J5	7.5	8.33	9.21	1	12.9	46.6	100
LTVA8.0AJ	LTVA8.0CJ	8J	8.0	8.89	9.83	1	13.6	44.2	50
LTVA8.5AJ	LTVA8.5CJ	8J5	8.5	9.44	10.40	1	14.4	41.7	20
LTVA9.0AJ	LTVA9.0CJ	9J	9.0	10.00	11.10	1	15.4	39.0	10
LTVA10AJ	LTVA10CJ	10J	10.0	11.10	12.30	1	17.0	35.3	5
LTVA11AJ	LTVA11CJ	11J	11.0	12.20	13.50	1	18.2	33.0	1
LTVA12AJ	LTVA12CJ	12J	12.0	13.30	14.70	1	19.9	30.2	1
LTVA13AJ	LTVA13CJ	13J	13.0	14.40	15.90	1	21.5	28.0	1
LTVA14AJ	LTVA14CJ	14J	14.0	15.60	17.20	1	23.2	25.9	1
LTVA15AJ	LTVA15CJ	15J	15.0	16.70	18.50	1	24.4	24.6	1
LTVA16AJ	LTVA16CJ	16J	16.0	17.80	19.70	1	26.0	23.1	1
LTVA17AJ	LTVA17CJ	17J	17.0	18.90	20.90	1	27.6	21.8	1
LTVA18AJ	LTVA18CJ	18J	18.0	20.00	22.10	1	29.2	20.6	1
LTVA20AJ	LTVA20CJ	20J	20.0	22.20	24.50	1	32.4	18.6	1
LTVA22AJ	LTVA22CJ	22J	22.0	24.40	26.90	1	35.5	16.9	1
LTVA24AJ	LTVA24CJ	24J	24.0	26.70	29.50	1	38.9	15.5	1
LTVA26AJ	LTVA26CJ	26J	26.0	28.90	31.90	1	42.1	14.3	1
LTVA28AJ	LTVA28CJ	28J	28.0	31.10	34.40	1	45.4	13.3	1
LTVA30AJ	LTVA30CJ	30J	30.0	33.30	36.80	1	48.4	12.4	1
LTVA33AJ	LTVA33CJ	33J	33.0	36.70	40.60	1	53.3	11.3	1
LTVA36AJ	LTVA36CJ	36J	36.0	40.00	44.20	1	58.1	10.4	1
LTVA40AJ	LTVA40CJ	40J	40.0	44.40	49.10	1	64.5	9.3	1
LTVA43AJ	LTVA43CJ	43J	43.0	47.80	52.80	1	69.4	8.7	1
LTVA45AJ	LTVA45CJ	45J	45.0	50.00	55.30	1	72.7	8.3	1
LTVA48AJ	LTVA48CJ	48J	48.0	53.30	58.90	1	77.4	7.8	1
LTVA51AJ	LTVA51CJ	51J	51.0	56.70	62.70	1	82.4	7.3	1
LTVA54AJ	LTVA54CJ	54J	54.0	60.00	66.30	1	87.1	6.9	1
LTVA58AJ	LTVA58CJ	58J	58.0	64.40	71.20	1	93.6	6.5	1
LTVA60AJ	LTVA60CJ	60J	60.0	66.70	73.70	1	96.8	6.2	1
LTVA64AJ	LTVA64CJ	64J	64.0	71.10	78.60	1	103.0	5.9	1
LTVA70AJ	LTVA70CJ	70J	70.0	77.80	86.00	1	113.0	5.3	1
LTVA75AJ	LTVA75CJ	75J	75.0	83.30	92.10	1	121.0	5.0	1
LTVA78AJ	LTVA78CJ	78J	78.0	86.70	95.80	1	126.0	4.8	1
LTVA85AJ	LTVA85CJ	85J	85.0	94.40	104.00	1	137.0	4.4	1
LTVA90AJ	LTVA90CJ	90J	90.0	100.00	111.00	1	146.0	4.1	1
LTVA100AJ	LTVA100CJ	100J	100.0	111.00	123.00	1	162.0	3.7	1
LTVA110AJ	LTVA110CJ	110J	110.0	122.00	135.00	1	177.0	3.4	1
LTVA120AJ	LTVA120CJ	120J	120.0	133.00	147.00	1	193.0	3.1	1
LTVA130AJ	LTVA130CJ	130J	130.0	144.00	159.00	1	209.0	2.9	1
LTVA150AJ	LTVA150CJ	150J	150.0	167.00	185.00	1	243.0	2.5	1
LTVA160AJ	LTVA160CJ	160J	160.0	178.00	197.00	1	259.0	2.3	1
LTVA170AJ	LTVA170CJ	170J	170.0	189.00	209.00	1	275.0	2.2	1
LTVA180AJ	LTVA180CJ	180J	180.0	201.00	222.00	1	292.0	2.1	1
LTVA190AJ	LTVA190CJ	190J	190.0	211.00	233.00	1	308.0	2.0	1
LTVA200AJ	LTVA200CJ	200J	200.0	224.00	247.00	1	324.0	1.9	1
LTVA210AJ	LTVA210CJ	210J	210.0	237.00	263.00	1	340.0	1.8	1
LTVA220AJ	LTVA220CJ	220J	220.0	246.00	272.00	1	356.0	1.7	1

Notes: For bidirectional type having V_R of 10V and less, the I_R limit is double.

Ratings and Characteristics Curves ($T_A = 25^\circ\text{C}$ unless otherwise noted)

Figure 1. Peak Pulse Power Rating Curve

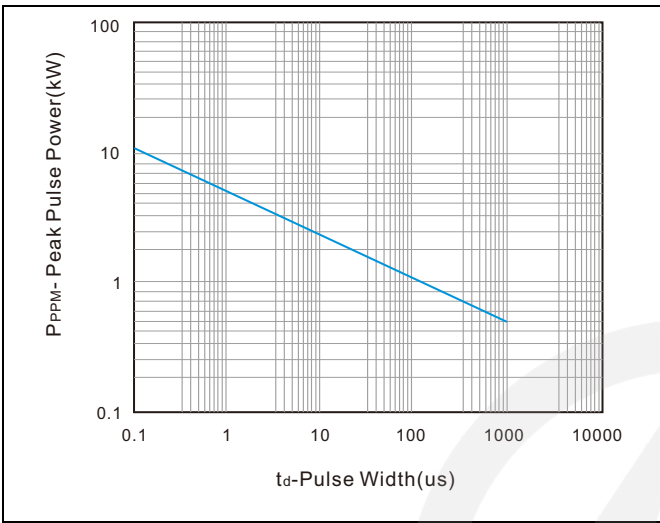

Figure 4. Typical Junction Capacitance

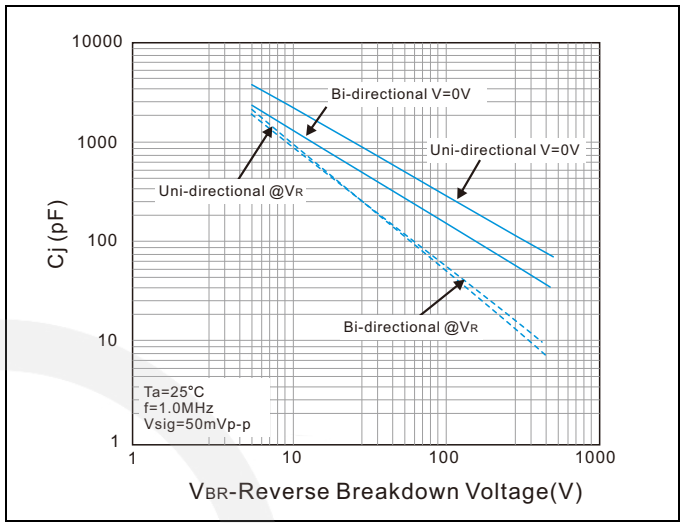

Figure 2. Pulse Derating Curve

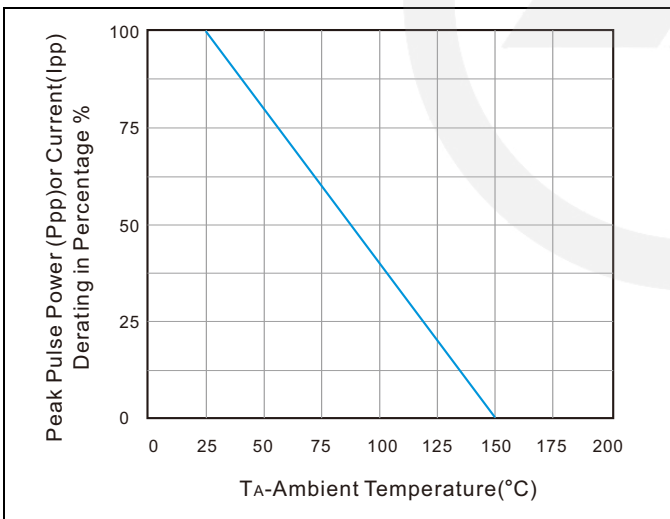

Figure 5. Steady State Power Dissipation Derating Curve

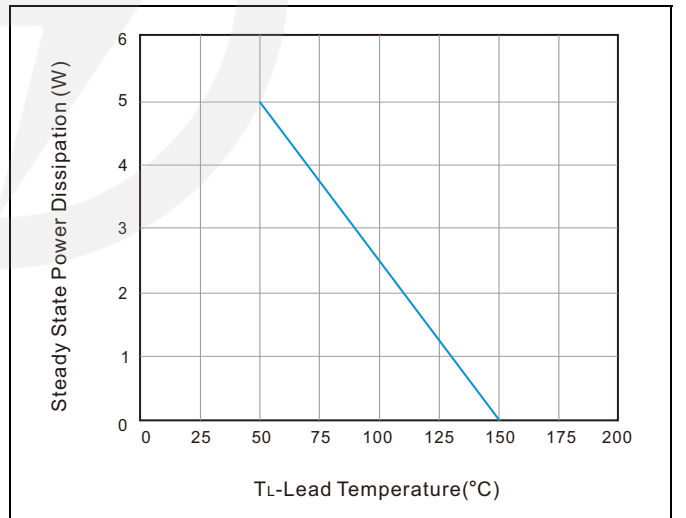

Figure 3. Pulse Waveform

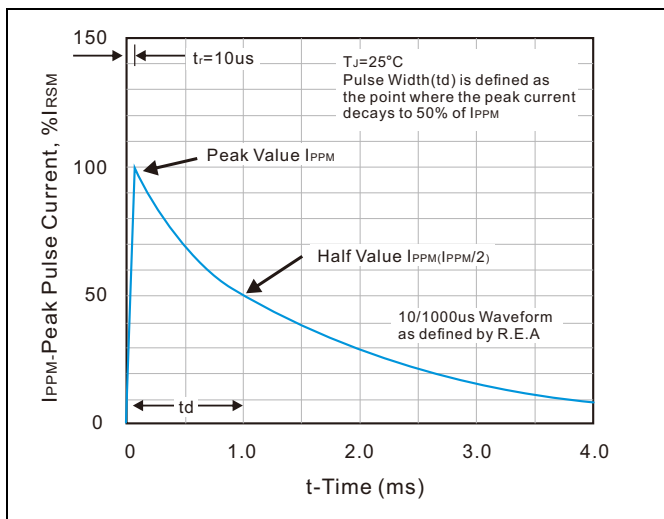
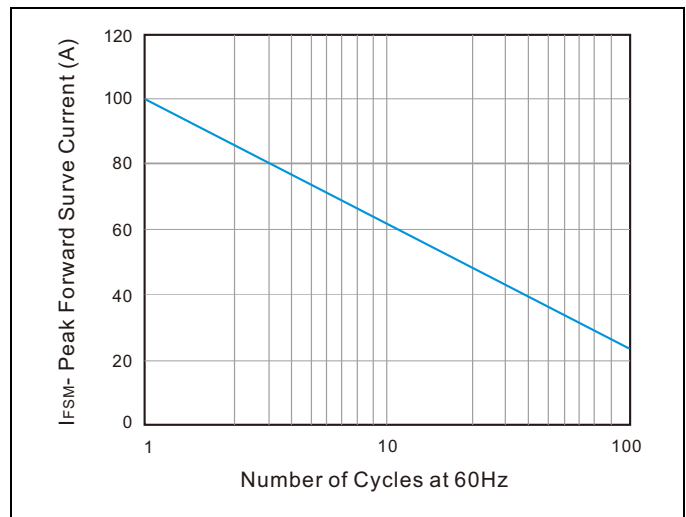
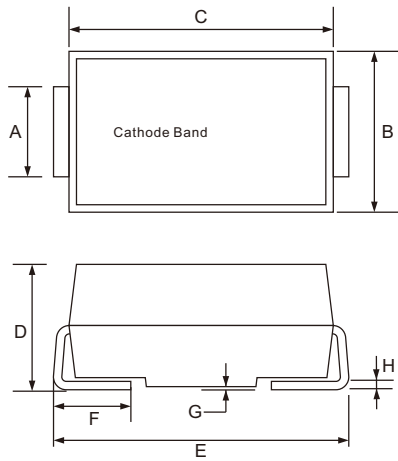

Figure 6. Maximum Non-Repetitive Forward Surge Current Uni-Directional Only



SMA Package Outline



Unit : mm

SYMBOL	DIMENSIONS	
	MIN.	MAX.
A	1.25	1.65
B	2.30	2.79
C	4.00	4.75
D	1.90	2.50
E	4.70	5.28
F	0.76	1.52
G	0.203 TYP.	
H	0.15	0.31

SMA Suggested Pad Layout

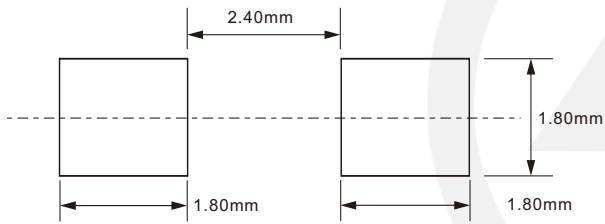

Note:

1. Controlling dimension: in millimeters.
2. General tolerance: $\pm 0.05\text{mm}$
3. The pad layout is for reference purpose only.

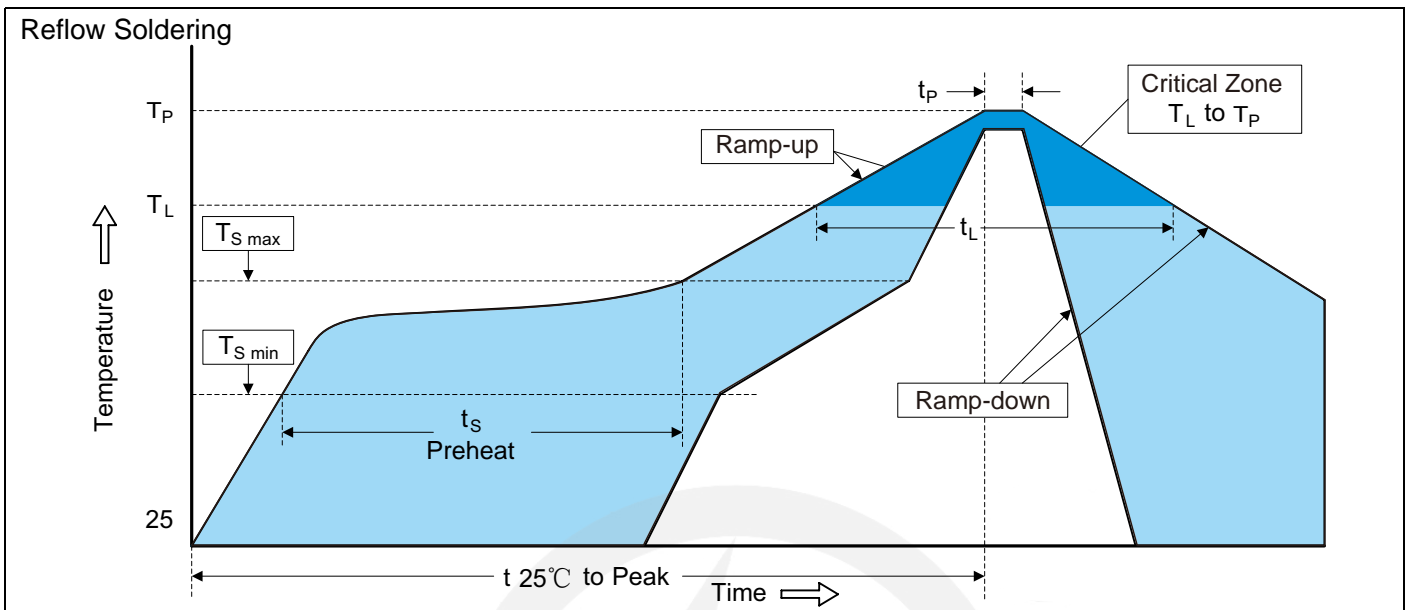
Recommended Soldering Conditions

Recommended Conditions

Profile Feature	Pb-Free Assembly
Average ramp-up rate (T_L to T_P)	3°C/second max.
Preheat -Temperature Min ($T_{S\ min}$) -Temperature Max ($T_{S\ max}$) -Time (min to max) (t_s)	150°C 200°C 60-180 seconds
$T_{S\ max}$ to T_L -Ramp-up Rate	3°C/second max.
Time maintained above: -Temperature (T_L) -Time (t_L)	217°C 60-150 seconds
Peak Temperature (T_P)	260°C
Time within 5°C of actual Peak Temperature (t_P)	20-40 seconds
Ramp-down Rate	6°C/second max.
Time 25°C to Peak Temperature	8 minutes max.

Packaging

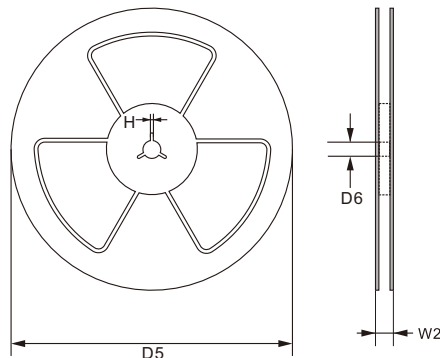
13" Reel

 D5 $\Phi 330.0 \pm 2.0$

 D6 $\Phi 13.5 \pm 0.5$

 H 2.5 ± 1.0

 W2 16.0 ± 2.0

Quantity: 5000PCS